



Model: WS NC FOR IPAD 10TH GEN WITH GRILLS +ETHERNET

Model No.: 002-1-925E-WG

Family: WALL-SMART

DWG NO.002-4-925E-WG-SPC

PRODUCT SPEC.

REVISION A

DATE 28/MAY/2024



Make Your Wall Smart

“WS NC FOR IPAD 10TH GEN WITH GRILLS +ETHERNET”

- Product description:

The “WS NC FOR IPAD 10TH GEN WITH GRILLS +ETHERNET” is a wall adapter for in-wall flush installation of an iPad 10th Gen.

The “WS NC FOR IPAD 10TH GEN WITH GRILLS +ETHERNET” firmly mounts the iPad while allowing easy insertion, removal and operation.

Key features and benefits:

- iPad is recessed 1.4mm [0.055"] into the wall surface.
- Wall mount may be mounted in any orientation.
- Includes depth calibration mechanism.
- Includes 10/100 ethernet connectivity.
- The wall mount contains audio grills.
- Paintable with the wall paint in any color and texture.
- Allows easy insertion and removal of the iPad.
- The adapter is supplied unpainted (To be painted after installation as part of the wall).
- Designed to be installed in ½" drywall. Installation of the Wall-Smart adapter is straight-forward. Installation process is similar to drywall construction procedures.
- For installation in concrete/block wall use “CONCRETE BOX 373X268” P/N 100-1-682 (sold separately) according installation instruction 10-04-00103-INS in <http://www.wall-smart.com/faq>
- Designed for the use with Apple iPad 10th Gen. (iPad is not included).
- Adapter kit contains:
 1. Wall adapter (X1)

Key properties:

- Dimensions: (W/H/D): 372mm (14.64")/ 266.7mm (10.5")/ 38.9mm(1.53")
- Power Supply: Wall mount includes POE to USB converter with Ethernet. The installer should connect the wall mount to an IEEE 802.3at POE+ power source via CAT5/6 cable and RJ45 connector. (Please verify the power source can supply up to 25.5W)
- See Page 3 For ethernet configuration.
- In case Ethernet connectivity is not necessary, consider using SKU# 002-1-925-WG with charging capability only.
- Weight: 1.3Kg, 2.86lbs.
- Material: Moisture resistant MDF (compliant with TSCA Title VI)
- To be installed in ½" drywall (for installation in 5/8" drywall use 1/8" shim pack P/N 10-01-067 (sold separately)).

iPad® is a trademark of Apple Inc., registered in the U.S. and other countries.

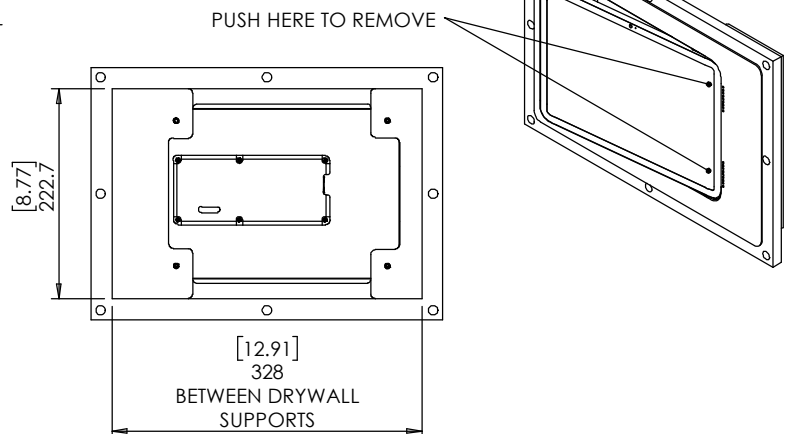
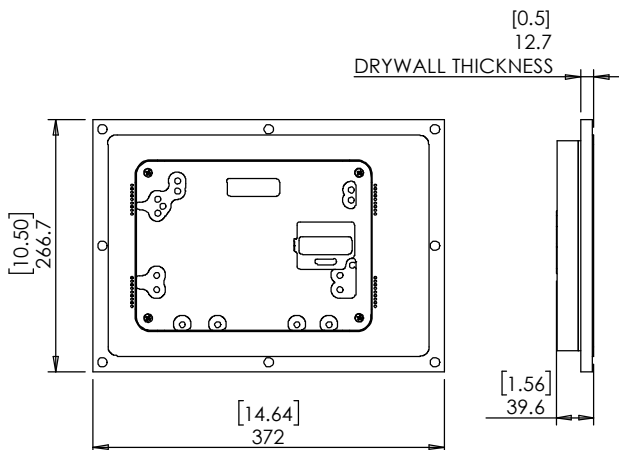
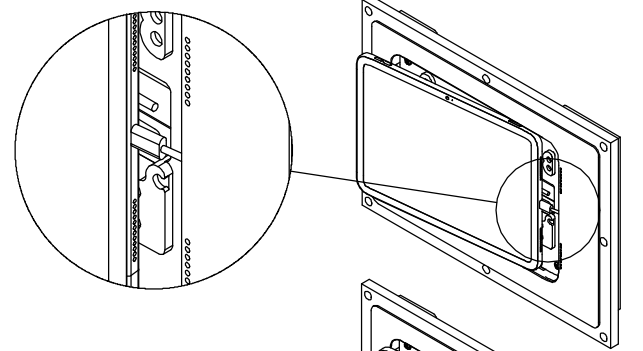
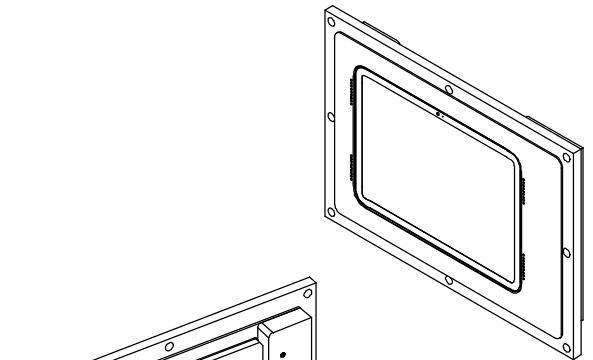
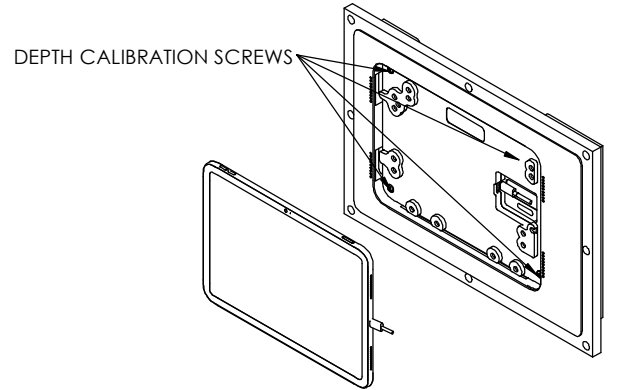



Model: WS NC FOR IPAD 10TH GEN WITH GRILLS +ETHERNET

Family: WALL-SMART

DWG NO. 002-4-925E-WG-SPC

Model No.: 002-1-925E-WG

PRODUCT SPEC.

REVISION A

DATE 28/MAY/2024

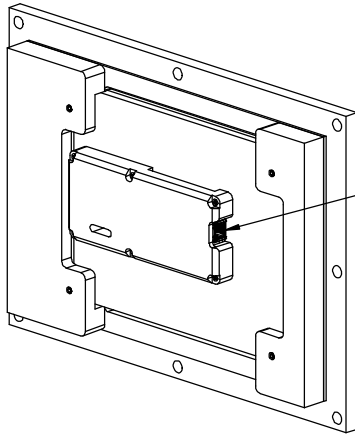

Before installation of the wall mount, connect a 48V IEEE 802.3at POE+ power source via a CAT5/6 cable and RJ45 connector to the POE to USB converter with ethernet.

If required, it is possible to gradually unscrew 4 screws, remove the platform and connect the POE cable after the wall mount is installed.

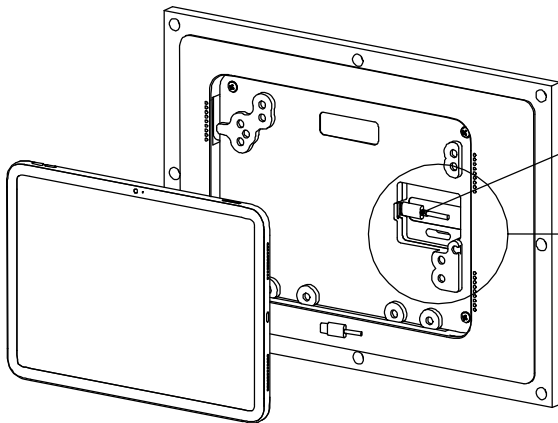
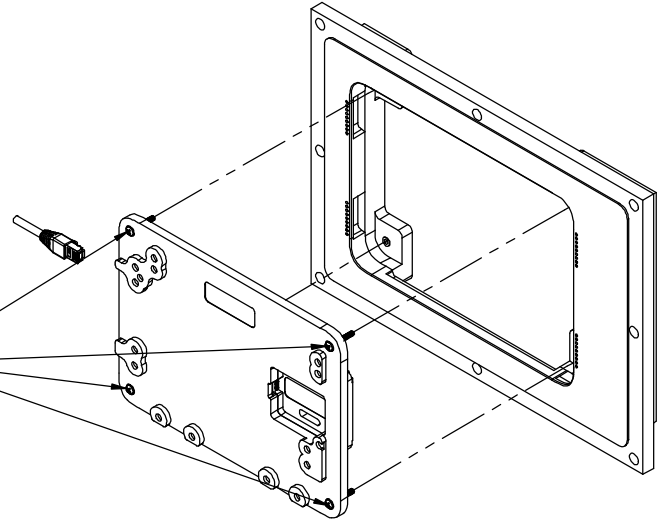

Connect iPad USB-C cable to POE to USB converter with ethernet

Organize the cable in the cable slit

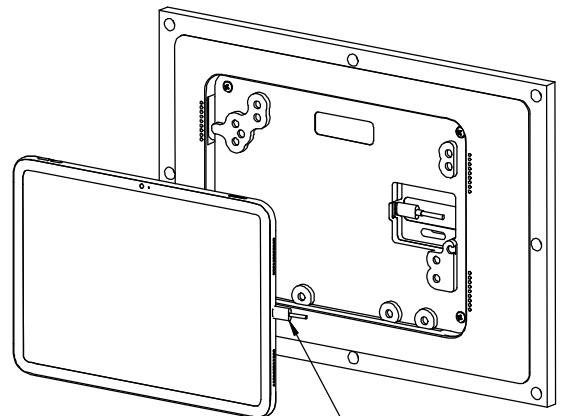
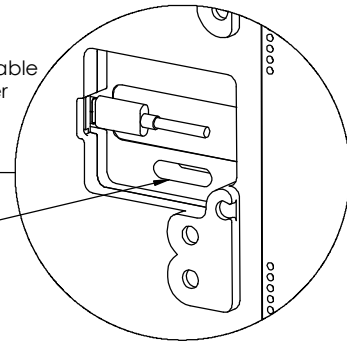

Connect USB-C connector to the iPad and insert iPad

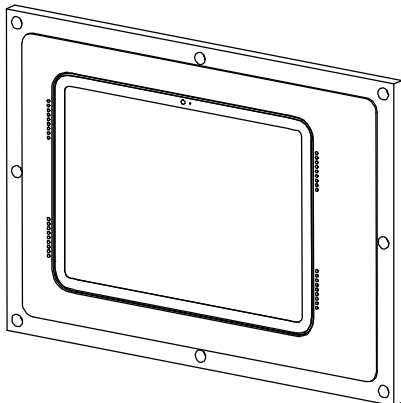



Model: WS NC FOR IPAD 10TH GEN WITH GRILLS +ETHERNET

Family: WALL-SMART

DWG NO. 002-4-925E-WG-SPC

Model No.: 002-1-925E-WG

PRODUCT SPEC.

REVISION A

DATE 28/MAY/2024



POE to USB converter with Ethernet - Product Specifications

- USB Connector: Type C
- Data Rate: 10/100
- Input Voltage Range: 44-56 volts (IEEE 802.3at compliant)
- Max Power Output: 25 watts
- Operating Humidity: 5% to 90%
- Operating Temperature Range: -10 – 60c
- Output Voltage: 5V,2.6A; 9V,1.78A; 12V,1.34A; 15V,1.37A; 20V,1.15A
- Power Input: 25.5 watts
- iPad operation system version must be iOS 12.2 or later.

Connection steps:

1. Plug the RJ-45 connector into an IEEE 802.3at PoE (POE+) with a data source.
2. Ensure the device you're connecting to is on and logged in.
3. Plug the USB-C connector into the mount.

The converter will automatically set up the network connection with your device and begin charging.

Configuring the IP:

1. Navigate to Settings and go to "Ethernet".
2. After selecting you'll see all the options for PoE Texas LAN, and your IPV4 IP address information. If it shows "Automatic", that means you're getting a dynamically assigned IP address.
3. If you'd like to reconfigure the IP address, DNS, and HTTP Proxy settings, you can do that here.
The most used option will be fixing your IP address by selecting the "Automatic" button.

