



Model: WS NC FOR IPAD 10TH GEN - WITHOUT GRILLS

Family: WALL-SMART

DWG NO. 002-4-925-NG-SPC



Model No.: 002-1-925-NG

PRODUCT SPEC.

REVISION A

DATE 22/DEC./2022

**Make Your Wall Smart**

**“WS NC FOR IPAD 10TH GEN - WITHOUT GRILLS” - Product description:**

The “WS NC FOR IPAD 10TH GEN - WITHOUT GRILLS” is a wall adapter for in-wall flush installation of an iPad 10<sup>th</sup> Gen.

The “WS NC FOR IPAD 10TH GEN - WITHOUT GRILLS” firmly mounts the iPad while allowing easy insertion, removal and operation.

**Key features and benefits:**

- iPad is recessed 1.4mm [0.055”] into the wall surface.
- Wall mount may be mounted in any orientation.
- Includes depth calibration mechanism.
- The wall mount **does not contain** audio grills.
- Paintable with the wall paint in any color and texture.
- Allows easy insertion and removal of the iPad.
- The adapter is supplied unpainted (To be painted after installation as part of the wall).
- Designed to be installed in ½” drywall. Installation of the Wall-Smart adapter is straight-forward. Installation process is similar to drywall construction procedures.
- For installation in concrete/block wall use “CONCRETE BOX 373X268” P/N 100-1-682 (sold separately) according installation instruction 10-04-00103-INS in <http://www.wall-smart.com/faq>
- Designed for the use with Apple iPad 10<sup>th</sup> Gen. (iPad is not included).
- Adapter kit contains:
  1. Wall adapter (X1)

**Key properties:**

- Dimensions: (W/H/D): 372mm (14.64”)/ 266.7mm (10.5”)/ 38.9mm(1.53”)
- Power Supply: Wall mount includes POE to USB converter. The installer should connect the wall mount to an IEEE 802.3at POE+ power source via CAT5/6 cable and RJ45 connector. (Please verify the power source can supply up to 25.5W)
- Standard mounts supplied with charging only. In case Ethernet connectivity required, please verify availability of SKU# 002-1-925E-NG.
- Weight: 1.3Kg, 2.86lbs.
- Material: Moisture resistant MDF (compliant with TSCA Title VI)
- To be installed in ½” drywall (for installation in 5/8” drywall use 1/8” shim pack P/N 10-01-067 (sold separately)).

iPad® is a trademark of Apple Inc., registered in the U.S. and other countries.

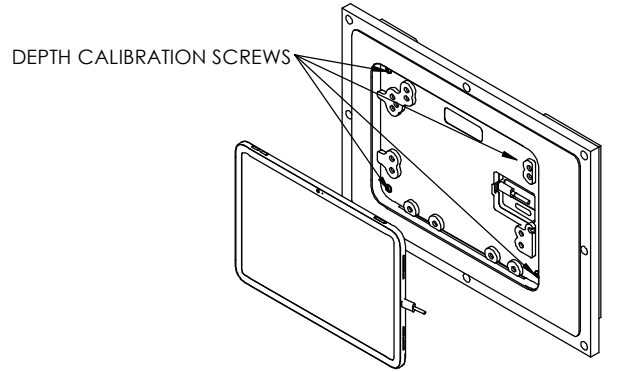

DEPTH CALIBRATION SCREWS

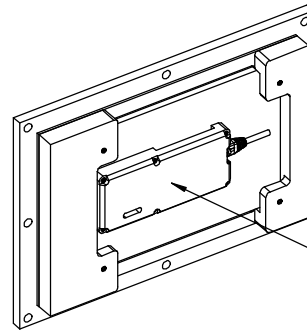
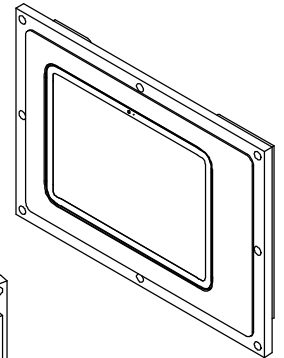

POE TO USB CONVERTER

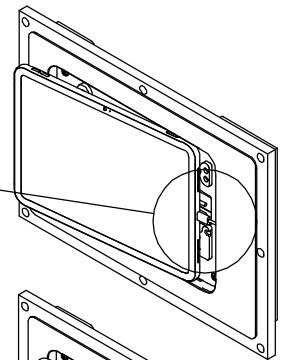
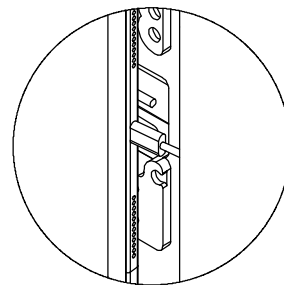

PUSH HERE TO REMOVE

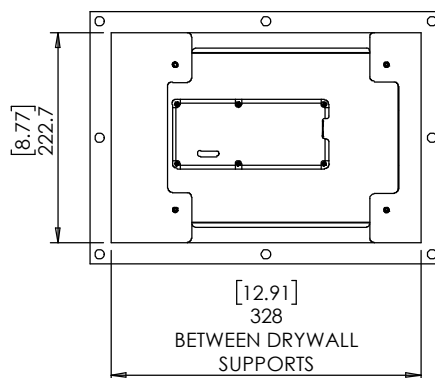
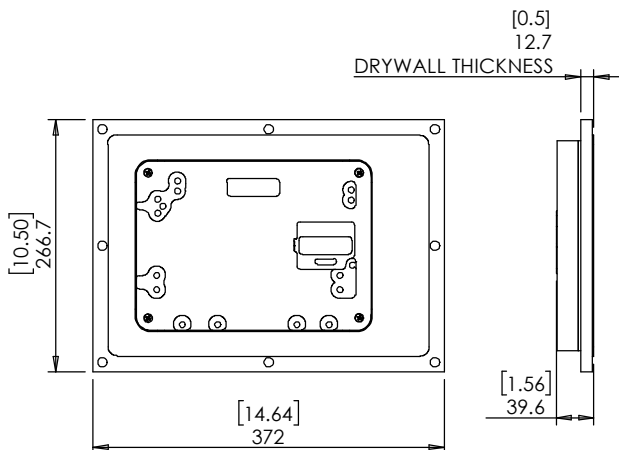
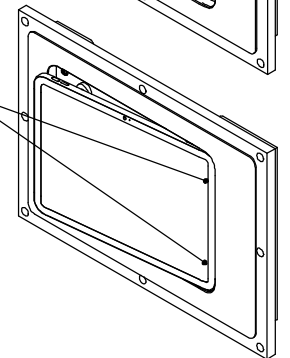



Model: WS NC FOR IPAD 10TH GEN - WITHOUT GRILLS

Family: WALL-SMART

DWG NO. 002-4-925-NG-SPC

Model No.: 002-1-925-NG

PRODUCT SPEC.

REVISION A

DATE 22/DEC./2022

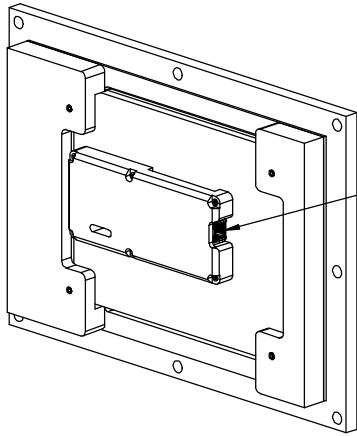

Before installation of the wall mount, connect a 48V IEEE 802.3at POE+ power source via a CAT5/6 cable and RJ45 connector to the POE to USB converter.

If required, it is possible to gradually unscrew 4 screws, remove the platform and connect the POE cable after the wall mount is installed.

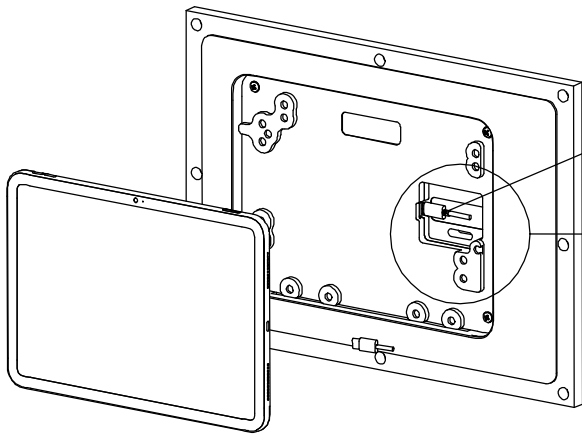
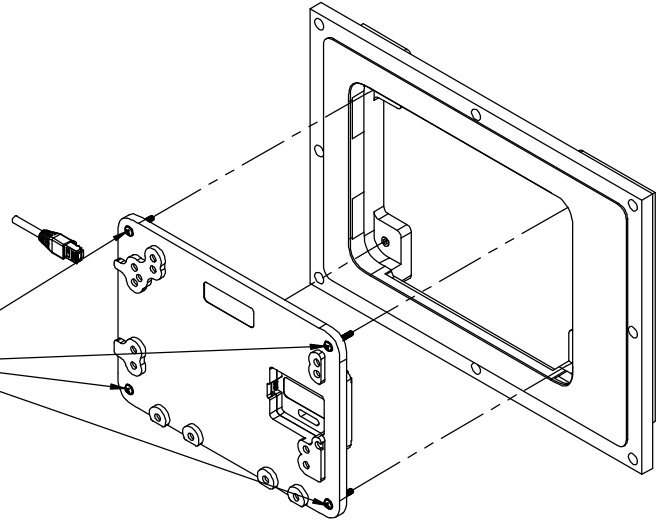

Connect iPad USB-C cable to POE to USB converter

Organize the cable in the cable slit

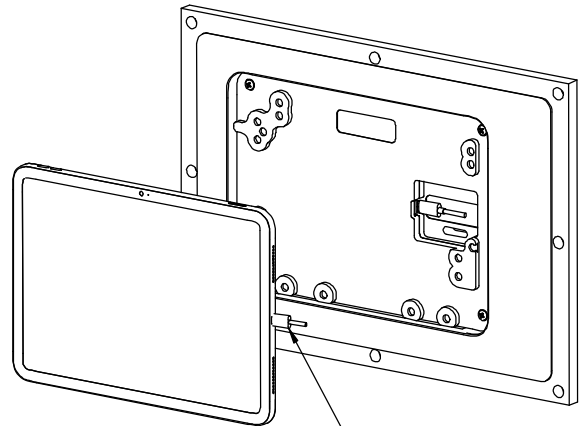
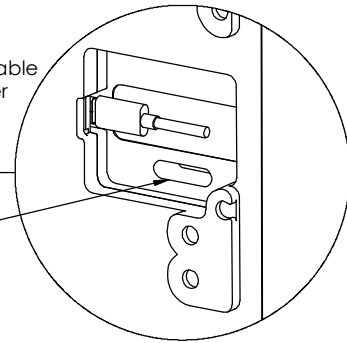

Connect USB-C connector to the iPad and insert iPad

