



Model: WS SB FOR CRESTRON HZ2-KPCN

Family: WALL-SMART

DWG NO. 10-04-466-SPC

Model No.: 10-01-466

PRODUCT SPEC.

REVISION B

DATE 07/JUNE/2023



Make Your Wall Smart

“WS SB FOR CRESTRON HZ2-KPCN” - Product description:

The “WS SB FOR CRESTRON HZ2-KPCN” is an adapter for in-wall flush installation of a HZ2-KPCN keypad in solid board walls.

The “WS SB FOR CRESTRON HZ2-KPCN” firmly mounts the touch screen while allowing easy access, insertion and removal.

Key features and benefits:

- Flush with the wall.
- Allows easy insertion and removal of the touch screen by manual push and magnet detachment.
- Installation adapter contains depth adjustment mechanism.
- Allowing installation in wide range of board thicknesses:
With spacer: 10.12mm ~ 22.5mm [0.39" ~ 0.88"] thick.
Without spacer: 21.72mm ~ 34.1mm [0.86" ~ 1.34"] thick.
- Internal light sensor is unusable in This wall mount.
- Installation kit contain:
 1. Routing template (X1)
 2. Wall adapter (X1)
 3. ST3x40 screws (X4)
 4. M3x12 screws (X2)
 5. keypad adapter (X1)
 6. M3 nuts (X2)
- Designed for HZ2-KPCN keypad (by Crestron) (keypad not included).

Key properties:

- Dimensions (W/H/D): 109.9mm (4.32")/ 152.1mm (5.99")/ 41.2mm (1.62")
- Power Supply: None (manual adapter).
- Weight: 0.42Kg, 0.924lbs.
- Material: Moisture resistant MDF

FOR INSTALLATION IN BOARD 10.12mm TO 22.5mm THICK USE ROUTING TEMPLATE AS INSTALLATION SPACER

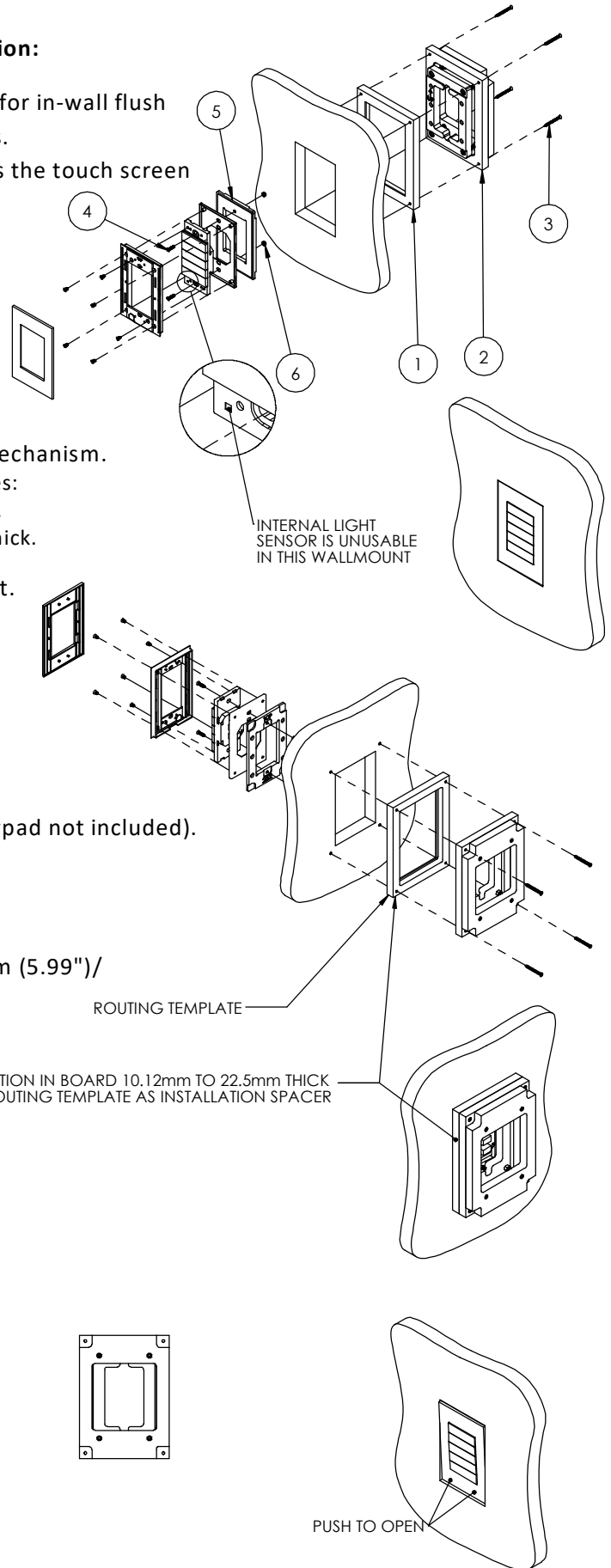

SOLID BOARD THICKNESS RANGE:
 10.12 ~ 22.5 [0.39"~0.88"] WITH SPACER
 21.72 ~ 34.1 [0.86" ~ 1.34"] WITHOUT SPACER

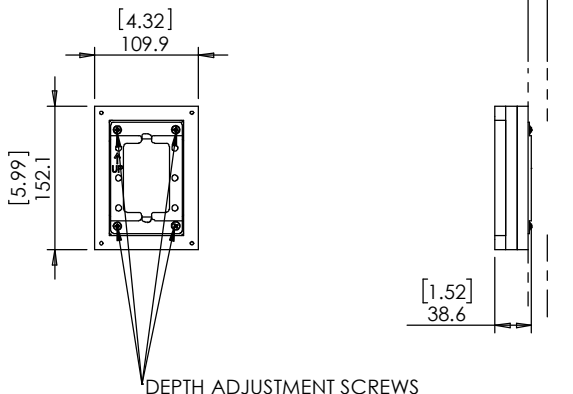



Model: WS SB FOR CRESTRON HZ-KPCN

Family: WALL-SMART

DWG NO. 10-04-466-SPC

Model No.: 10-01-466

PRODUCT SPEC.

REVISION A

DATE 24/JUNE/2018



ROUTING TEMPLATE

MARK SCREW LOCATIONS

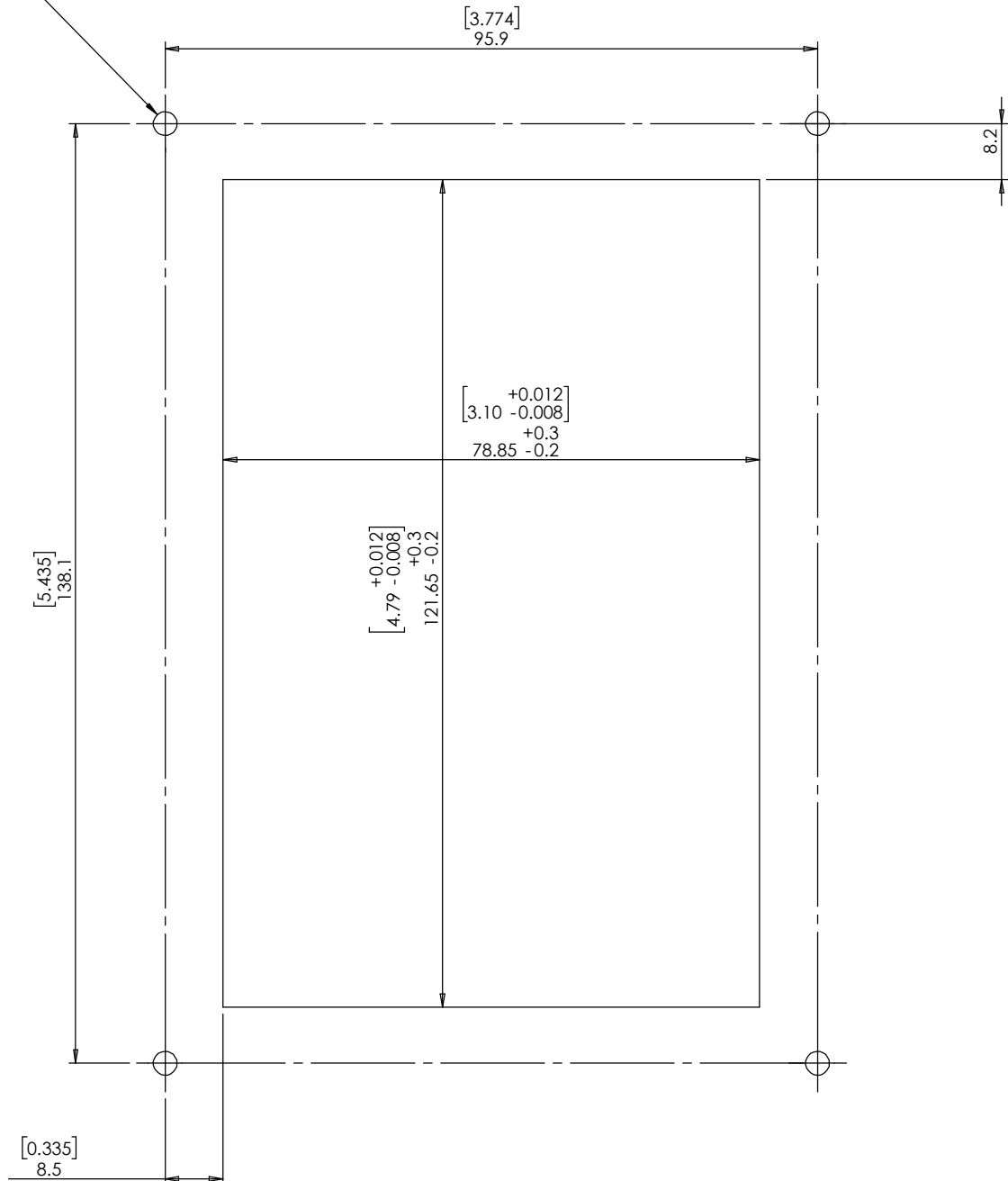

PRINT THIS PAGE 1:1