



Model: WS NC FOR ATLONA
AT-VTP-800 8" SCREEN

Family: WALL-SMART

DWG NO. 10-04-442-SPC



Model No.: 10-01-442

PRODUCT SPEC.

REVISION B

DATE 24/JUNE/2018

Make Your Wall Smart

WS NC FOR ATLONA AT-VTP-800 8" SCREEN - Product description:

The "WS NC FOR ATLONA AT-VTP-800 8" SCREEN" is an adapter for in-wall flush installation of a AT-VTP-800 Touch Screen.
The "WS NC FOR ATLONA AT-VTP-800 8" SCREEN" firmly mounts the touch screen while allowing easy access, insertion and removal.

Key features and benefits:

- Flush with the wall.
- Paintable with the wall paint in any color and texture.
- Allows easy insertion and removal of the keypad by manual push and magnet detachment of the Touch Screen tray.
- The adapter is supplied unpainted (To be painted after installation as part of the wall).
- Includes depth calibration mechanism.
- Designed to be installed in 1/2" drywall. Installation of the Wall-Smart adapter is straight-forward. Installation process is similar to drywall construction procedures. Before installation, read Wall-Smart installation instruction 10-04-00101-INS in <http://www.wall-smart.com/faq>
- For installation in concrete/block wall use "WS CONCRETE BOX 300X225" P/N 10-01-446 (sold separately) according installation instruction 10-04-00103-INS in <http://www.wall-smart.com/faq>
- Designed for the use with AT-VTP-800 Touch Screen (by ATLONA) (Touch Screen not included).
- Adapter kit contains:
 1. (X1) Wall adapter;
 2. (X1) Touch screen adapter
 3. (X4) M4 nuts
 4. (X4) M4X10 SCREWS

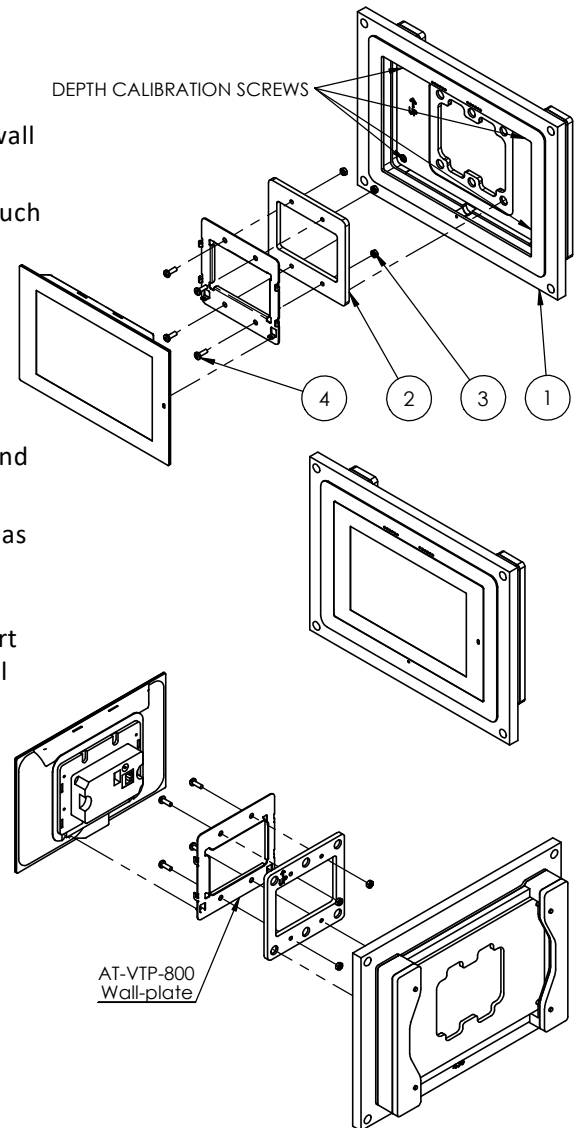

Key properties:

- Dimensions (W/H/D): 299.3mm (11.78")/ 224.3mm (8.83")/ 46.2mm (1.82")
- Power Supply: None (manual adapter).
- Weight: 0.7Kg, 1.54lbs.

