



Model: WS SB FOR ABB 3M TB/U6.8.1-CG Touch control

Family: WALL-SMART

DWG NO. 070-4-693-SPC



Model No.: 070-1-693

PRODUCT SPEC.

REVISION A  
DATE 09/MAR/2020

**Make Your Wall Smart**

**“WS SB FOR ABB 3M TB/U6.8.1-CG Touch control” - Product description:**

The “WS SB FOR ABB 3M TB/U6.8.1-CG Touch control” is an adapter for in-wall flush installation of a ABB 3M TB/U6.8.1-CG Touch control in solid board walls.

The “WS SB FOR ABB 3M TB/U6.8.1-CG Touch control” firmly mounts the keypad while allowing easy access, insertion and removal.

**Key features and benefits:**

- Allows easy insertion and removal by manual push.
- Wall mount contains depth calibration screws and spacer allowing installation in solid surface boards of 8 [0.31”] up to 34 [1.34”] thickness.
- Installation kit contain:
  1. X1 Wall adapter
  2. X1 Routing template
  3. X4 ST3x30 screws
  4. X1 Touch panel adapter
  5. X4 M3 nuts
  6. X4 M3x12 screws
- Designed for the use with ABB 3M TB/U6.8.1-CG Touch control (touch panel not included)

**Key properties:**

- Dimensions (W/H/D): 148mm (5.83”)/ 120mm (4.72”)/ 46.1mm (1.81”)
- Power Supply: None (manual adapter).
- Weight: 0.4Kg, 0.88lbs.
- Material: Moisture resistant MDF (compliant with TSCA Title VI)

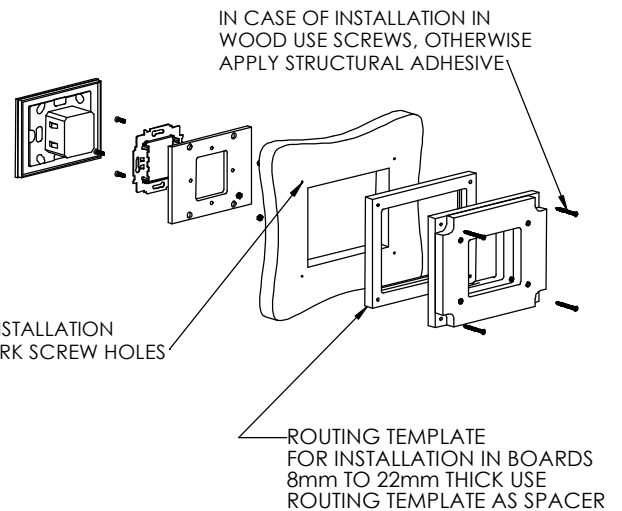
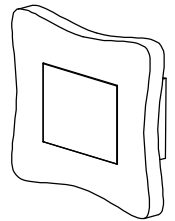
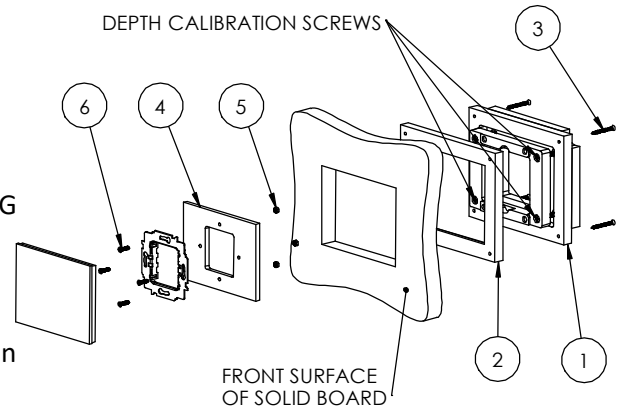

SOLID BOARD THICKNESS RANGE:  
8~ 22 [0.31~0.86] WITH SPACER  
20 ~ 34 [0.79~1.34] WITHOUT SPACER

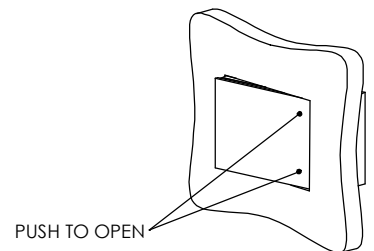
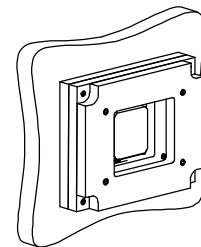
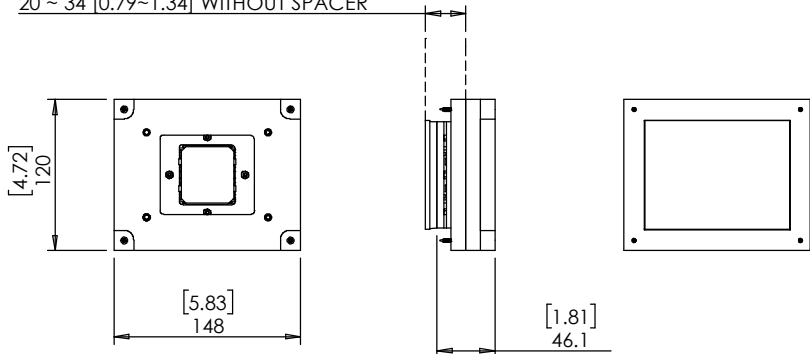



Model: WS SB FOR ABB 3M  
TB/U6.8.1-CG Touch control

Family: WALL-SMART

DWG NO. 070-4-693-SPC



Model No.: 070-1-693

PRODUCT SPEC.

REVISION A

DATE 09/MAR/2020

## ROUTING TEMPLATE for 070-1-693

MARK SCREW  
LOCATIONS

