



Model: WS NC FOR PALLADIOM THERMOSTAT HQWT GLASS & MATTE

Family: WALL-SMART

DWG NO. 058-4-884-SPC



Model No.: 058-1-884

PRODUCT SPEC.

REVISION B

DATE 17/MAY/2022

**Make Your Wall Smart**

**WS NC FOR PALLADIOM THERMOSTAT HQWT GLASS & MATTE - Product description:**

The "WS NC FOR PALLADIOM THERMOSTAT HQWT GLASS & MATTE" is an adapter for in-wall flush installation of a Palladiom HQWT GLASS thermostat. The "WS NC FOR PALLADIOM THERMOSTAT HQWT GLASS & MATTE" firmly mounts the device while allowing easy access, insertion and removal.

**Key features and benefits:**

- Flush with the wall.
- Paintable with the wall paint in any color and texture.
- Allows easy insertion and removal of the device.
- Includes depth calibration mechanism.
- The adapter is supplied unpainted (To be painted after installation as part of the wall).
- Designed to be installed in 1/2" drywall. Installation of the Wall-Smart adapter is straight-forward. Installation process is similar to drywall construction procedures. Before installation, read Wall-Smart installation instruction 10-04-00101-INS in <http://www.wall-smart.com/faq>
- For installation in concrete/block wall use "WS Concrete Box 178x178" P/N 10-01-159 (sold separately) according installation instruction 10-04-00103-INS in <http://www.wall-smart.com/faq>
- Designed for Lutron HomeWorks Palladiom HVAC Solution - glass & matte finish (HQWT-T-HW-XXX-A) (thermostat not included).
- Adapter kit contains:
  1. (X1) Wall adapter
  2. (X1) Device adapter

**Key properties:**

- Dimensions (W/H/D):177mm (6.97")/ 177mm (6.97")/ 45.2mm (1.78").
- Power Supply: None (manual adapter).
- Weight: 0.6Kg, 1.32lbs.
- Material: Moisture resistant MDF (compliant with TSCA Title VI).

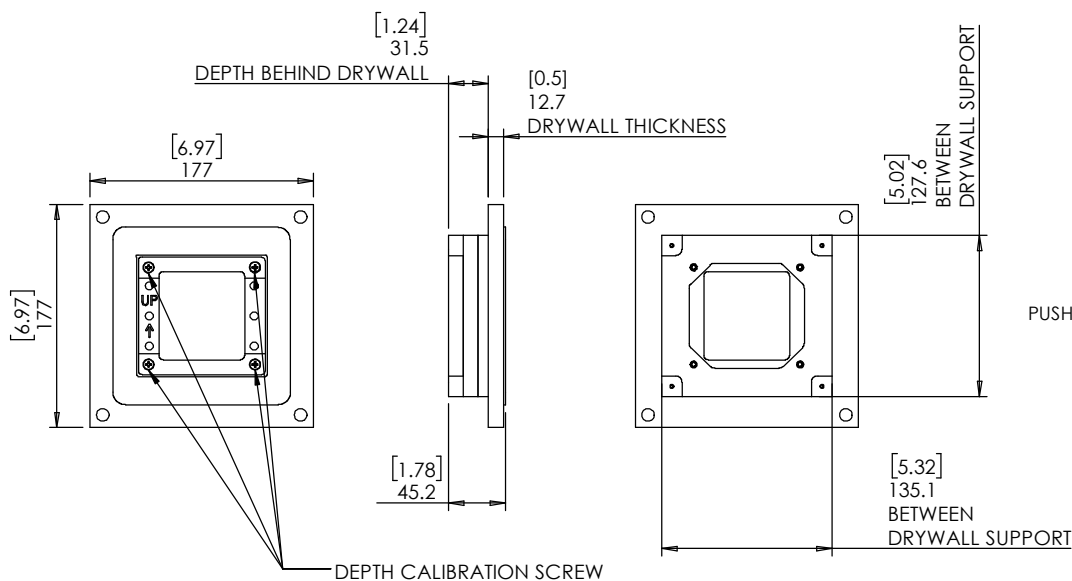
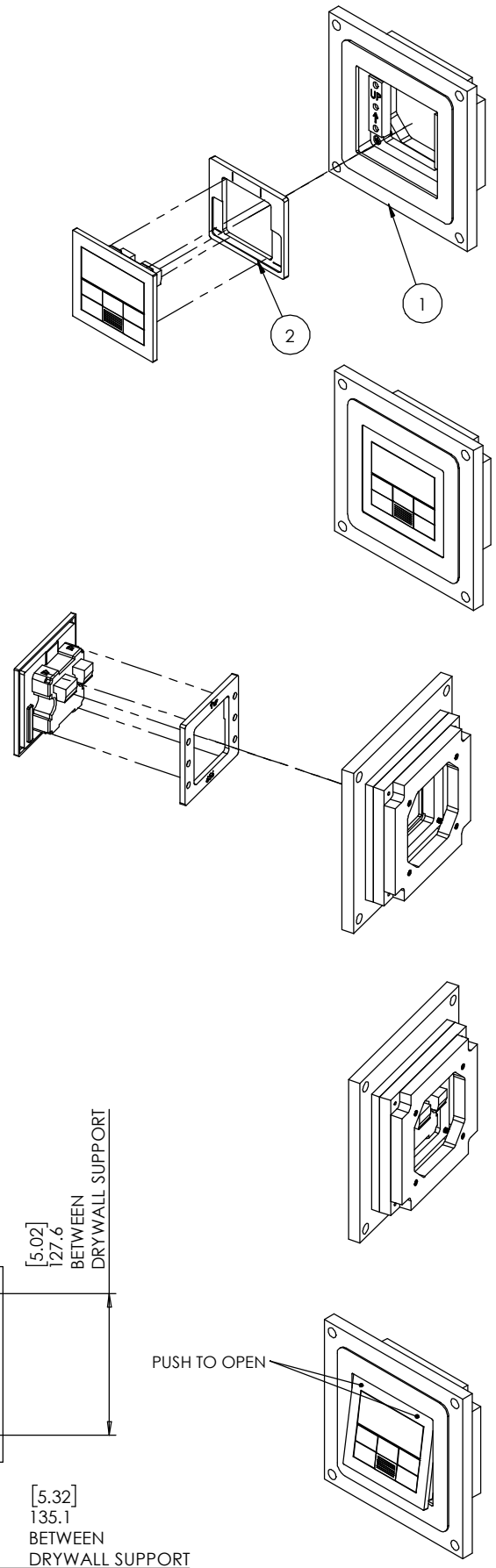

PUSH TO OPEN