



Model: WS SB FOR SAVANT ASCEND WFB 3Gang

Family: WALL-SMART

DWG NO. 028-4-909-SPC



Model No.: 028-1-909

PRODUCT SPEC.

REVISION A

DATE 06/SEP/2022

Make Your Wall Smart

WS SB FOR SAVANT ASCEND WFB 3G – Product description:

The “WS SB FOR SAVANT ASCEND WFB 3G” is an adapter for in-wall flush installation of a Savant Ascend 3G keypad in solid board walls.

The “WS SB FOR SAVANT ASCEND WFB 3G” firmly mounts the device while allowing easy access, insertion and removal.

Key features and benefits:

- Flush with the wall.
- Allows easy maintenance access.
- Includes depth calibration mechanism and a spacer.
- allowing installation in wide range of board thicknesses:
With spacer: 6.93mm ~ 21.2mm [0.27" ~ 0.83"] thick.
Without spacer: 18.53mm ~ 32.8mm [0.73" ~ 1.29"] thick.
- Designed for the use with Savant Ascend WFB 3G keypad. (keypad not included)
- Use spacer as routing template.
- Installation kit contains:
 1. Wall adapter (x1)
 2. Spacer frame (Routing template) (x1)
 3. Keypad adaptor frame (X1)
 4. ST3x40 screws (x4)
 5. M3X12 Screws (x6)
 6. M3 nut (X6)

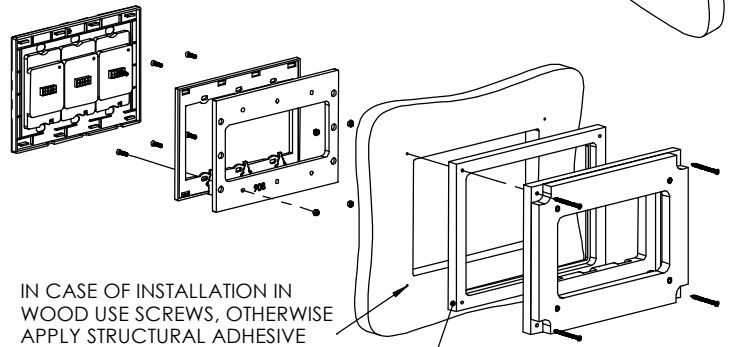
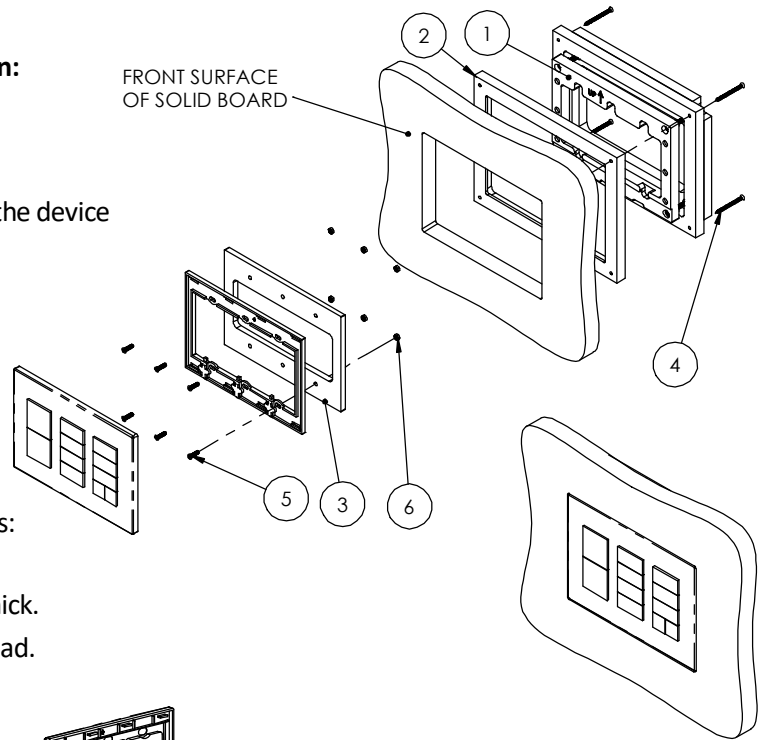

FOR INSTALLATION IN BOARDS 6.93mm TO 21.2mm THICK USE ROUTING TEMPLATE AS INSTALLATION SPACER

Key properties:

- Dimensions (W/H/D): 200.3mm (7.88")/ 152.2mm (5.99")/ 41.2mm (1.62")
- Power Supply: None (manual adapter).
- Weight: 0.47Kg, 1.01lbs.
- Material: Moisture resistant MDF (compliant with TSCA Title VI)

SOLID BOARD THICKNESS RANGE:
6.93 ~ 21.2 [0.27~0.83"] WITH SPACER
18.53 ~ 32.8 [0.73~1.29"] WITHOUT SPACER

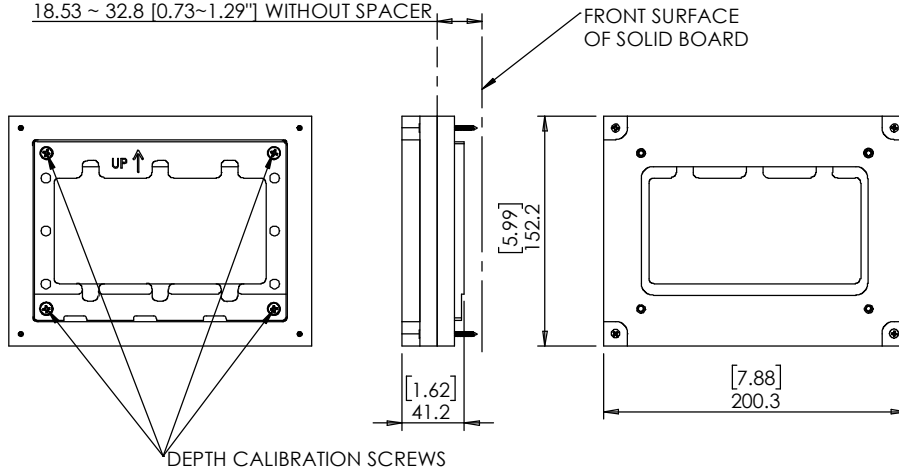

PUSH TO OPEN



Model: WS SB FOR SAVANT
ASCEND WFB 3Gang

Family: WALL-SMART

DWG NO. 028-4-909-SPC

Model No.: 028-1-909

PRODUCT SPEC.

REVISION A

DATE 06/SEP/2022



CUTOUT ROUTING TEMPLATE

028-1-909

SCALE 1:1

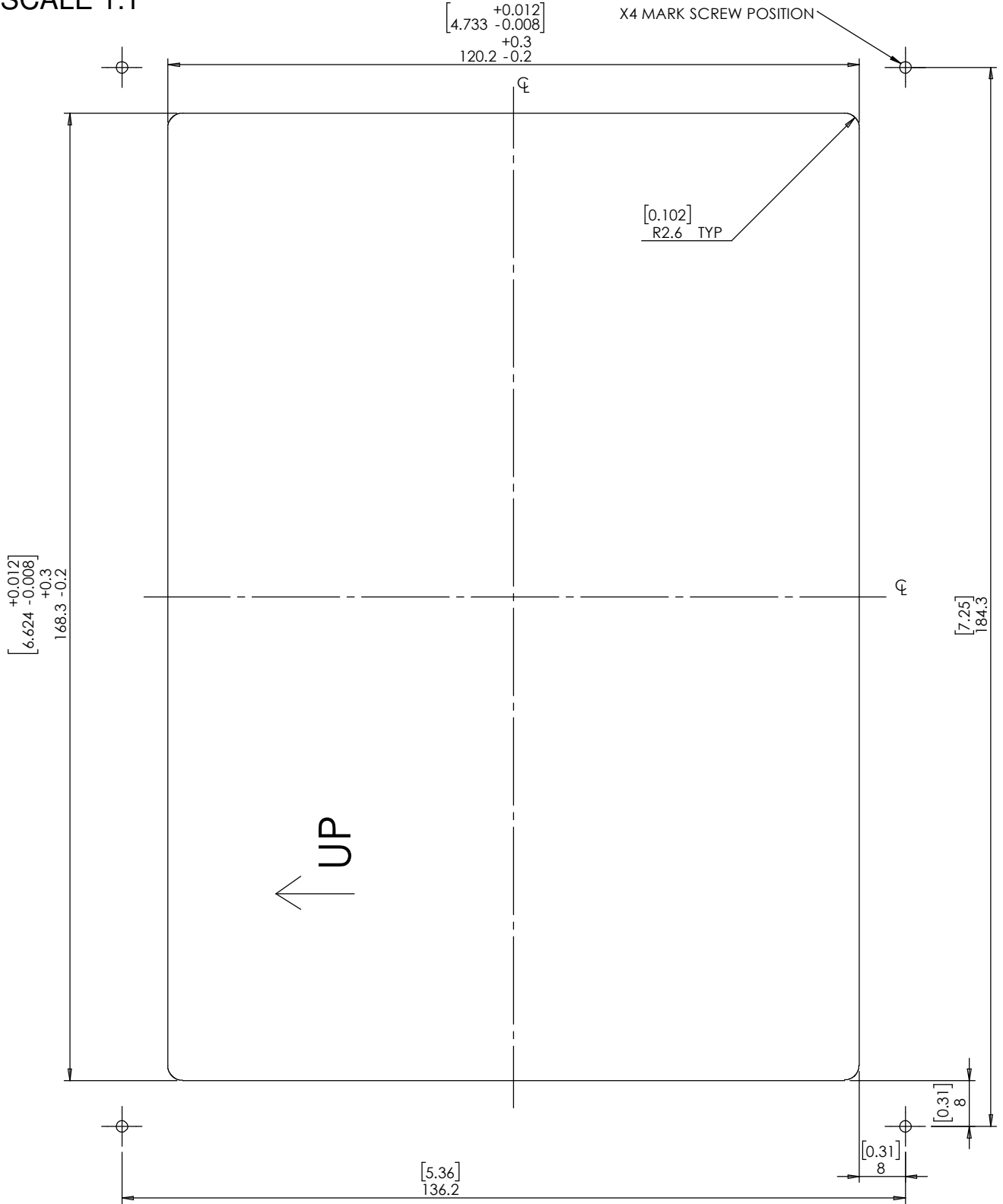

PRINT THIS PAGE 1:1 SCALE