



Model: WS RETROFIT FOR IPAD AIR 4&5
BLACK / WHITE / UNPAINTED

Model No.: 002-1-873-BL / -WH / -WO

Family: WALL-SMART
DWG NO. 002-4-873-SPC

PRODUCT SPEC. REVISION B
DATE 30/Oct./2022



Make Your Wall Smart

“WS RETROFIT FOR IPAD AIR 4&5” - Product description:

The “WS RETROFIT FOR IPAD AIR 4&5” is an adapter for in-wall nearly flush retrofit installation of iPad Air 4&5th Gen.

The “WS RETROFIT FOR IPAD AIR 4&5” firmly mounts the iPad while allowing easy insertion, removal and operation.

Key features and benefits:

- Nearly flush with the wall (4mm [0.16"] thick on-wall bezel).
- Wall mount may be mounted in any orientation.
- Designed for the use with iPad Air 4&5th Gen. (by Apple) (iPad is not included).
- Adapter kit contains:
 1. (X1) Wall adapter;
 2. (X1) Bezel;
 3. (X1) USB-C / USB-C 90deg adaptor;
- The bezel is supplied painted black (-BL), white (-WH) or unpainted (-WO).

Key properties:

- Dimensions: (W/H/D): 314.4mm (12.38")/ 232.3mm (9.15")/ 42.6mm (1.68")
- Power Supply: Wall mount includes POE to USB-C converter. The installer should connect the wall mount to an IEEE 802.3at POE+ power source via CAT6 cable and RJ45 connector. (Please verify the POE+ power source can supply 25.5W)
- Weight: 2.3Kg, 5.06lbs.
- Material: Moisture resistant MDF (compliant with TSCA Title VI)

iPad® is a trademark of Apple Inc., registered in the U.S. and other countries.

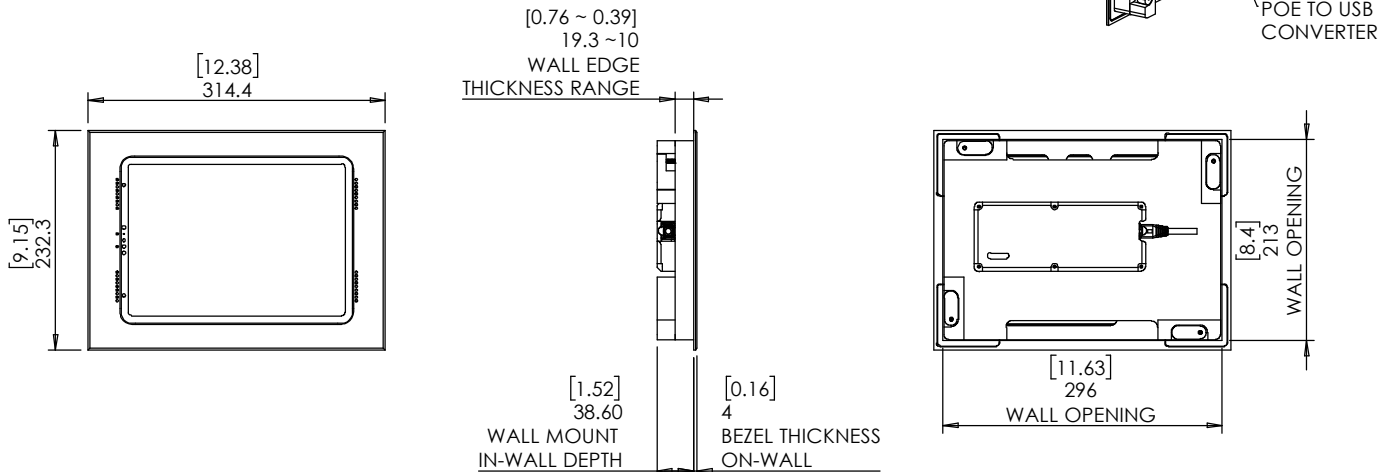
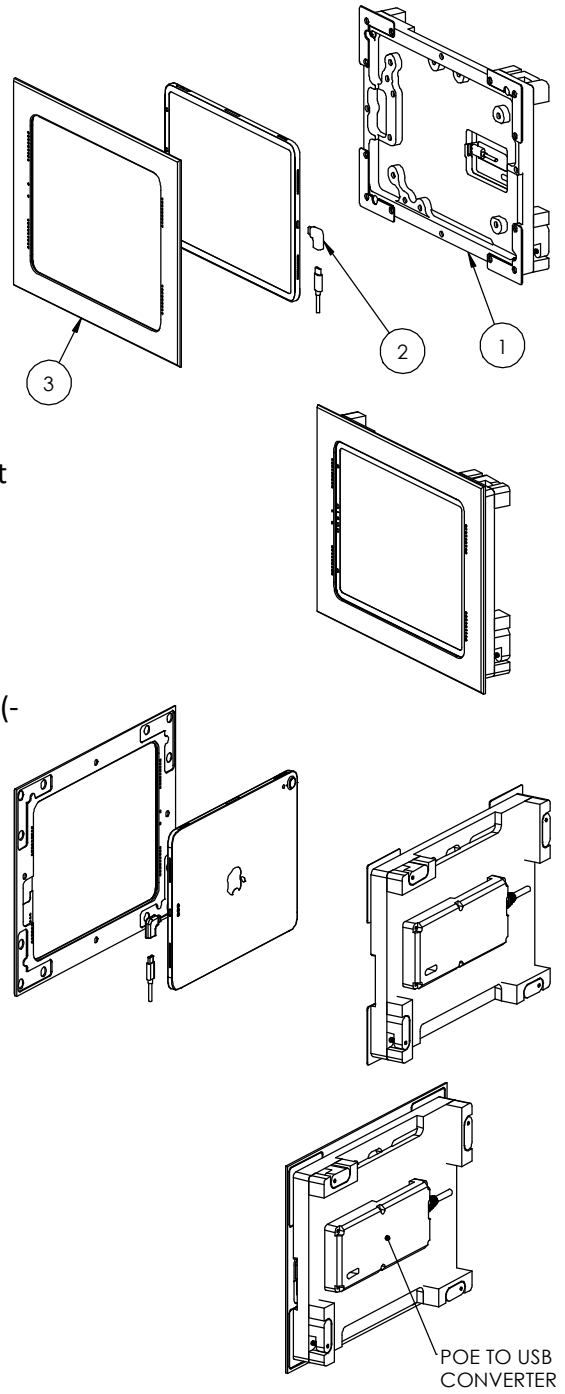



Model: WS RETROFIT FOR IPAD AIR 4&5
BLACK / WHITE / UNPAINTED

Family: WALL-SMART

DWG NO. 002-4-873-SPC

Model No.: 002-1-873-BL / -WH / -WO

PRODUCT SPEC.

REVISION B

DATE 30/Oct./2022

