



Model: WS RETROFIT FOR iPad MINI
BLACK / WHITE / UNPAINTED

Family: WALL-SMART

DWG NO. 002-4-609-SPC



Model No.: 002-1-609-BL/-WH/-WO

PRODUCT SPEC.

REVISION A
DATE 13/FEB/2020

Make Your Wall Smart

“WS RETROFIT FOR iPad MINI BLACK/WHITE/UNPAINTED” - Product description:

The “WS RETROFIT FOR iPad MINI” is an adapter for in-wall nearly flush retrofit installation of iPad mini®.

The “WS RETROFIT FOR iPad MINI” firmly mounts the iPad mini® while allowing easy insertion, removal and operation.

Key features and benefits:

- Nearly flush with the wall (4mm [0.16"] thick on-wall bezel).
- Wall mount may be mounted in any orientation.
- Allows easy insertion and removal of the iPad MINI.
- Wall mount contains depth calibration screws.
- Designed for the use with iPad mini®(by Apple) (iPad is not included).
- Adapter kit contains:
 1. (X1) Wall adapter;
 2. (X2) Wall-Smart rubber pads;
 3. (X1) Wall-Smart Pad Positioning Template;
 4. (X1) Bezel;
- The bezel is supplied painted black (-BL) , white (-WH) or unpainted (-WO).

Key properties:

- Dimensions: (W/H/D): 254.9mm (10.03")/ 188.5mm (7.42")/ 47.8mm (1.88")
- Power Supply: Wall mount includes POE to USB converter.
The installer should connect the wall mount to an IEEE 802.3af POE+ power source via CAT6 cable and RJ45 connector.
(Please verify the power source can supply up to 25.5W)
- Weight: 2.2Kg, 4.85lbs.
- Material: Moisture resistant MDF (compliant with TSCA Title VI)

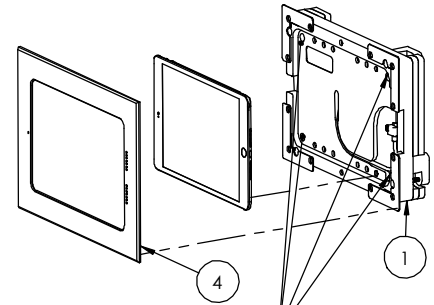

USE DEPTH CALIBRATION SCREWS TO ADJUST iPad POSITION

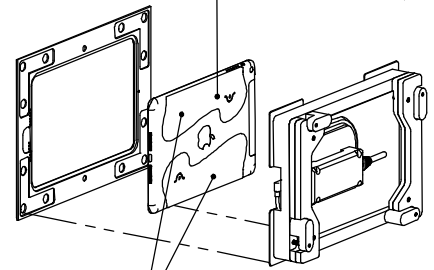
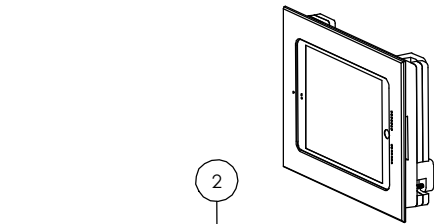

WALL-SMART RUBBER PADS

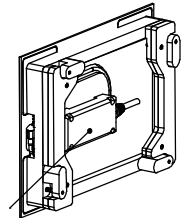

POE to USB converter.
connect a 48V IEEE 802.3af POE power source via a CAT5/6 cable and RJ45 connector

iPad® is a trademark of Apple Inc., registered in the U.S. and other countries.

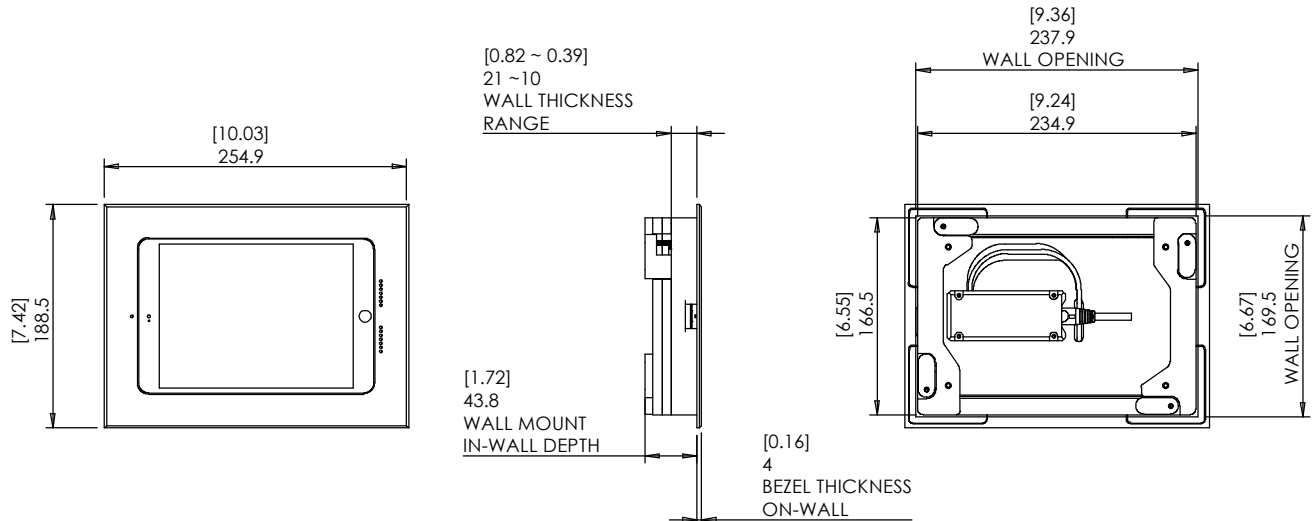



Model: WS RETROFIT FOR iPad MINI
BLACK / WHITE / UNPAINTED

Family: WALL-SMART

DWG NO. 002-4-609-SPC



Model No.: 002-1-609-BL/-WH/-WO

PRODUCT SPEC.

REVISION A

DATE 13/FEB/2020

Wall-Smart rubber pads installation:

1. Clean iPads back surface.
2. Position template.

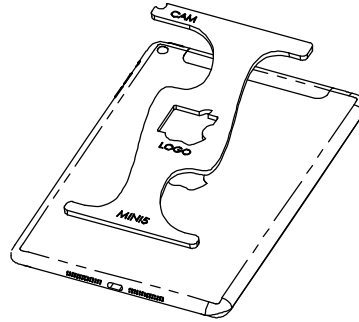

3. Align template cutouts with Apple logo and cam

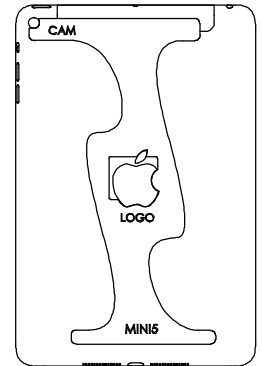

4. Remove protective tape of a rubber pad back adhesive.
5. Align rubber pad to template while maintaining the position of the template
6. Adhere the rubber pad to the iPad gradually from template to the iPad edge

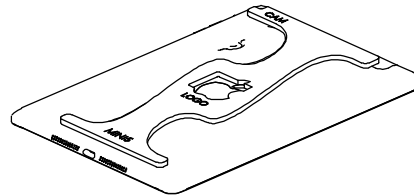

7. Press down from the center of the rubber pad and towards the pad edges to remove air bubbles.
8. Push down the edges of the rubber pad to close all gaps.
9. Repeat steps 4-8 for the second rubber pad.
10. Remove the template and wait 6mins before mounting.

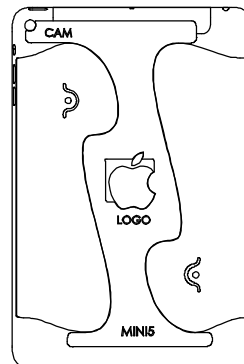
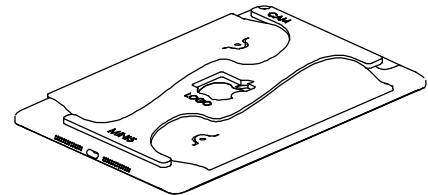



Model: WS RETROFIT FOR iPad MINI5
BLACK / WHITE / UNPAINTED

Family: WALL-SMART

DWG NO. 002-4-609-SPC



Model No.: 002-1-609-BL/-WH/-WO

PRODUCT SPEC.

REVISION A
DATE 13/FEB/2020

